



# S1 Turbo

**NEW:  
RETROFITTABLE  
PELLET UNIT**



**5<sup>XXL</sup> YEAR  
WARRANTY**  
subject to WARRANTY CONDITIONS

# Heating with firewood

For over 50 years, Froling has specialised in using wood as an efficient source of energy. Today the name Froling represents modern biomass heating technology. Froling firewood, wood chip and pellet boilers are successfully in operation all over Europe. All of our products are manufactured in our factories in Austria and Germany, and our extensive service network ensures that we can handle all inquiries quickly.



## The fuel: firewood (up to 56 cm)

Wood is a home-grown and environmentally friendly fuel, that is highly sustainable. It is CO<sub>2</sub> neutral and is not affected by international crises. The production of firewood and pellets ensures stable jobs in the industry. Looking at it from an environmental and economical point of view, wood is the ideal fuel. The quality class is determined by the wood used.



## The new S1 Turbo firewood boiler

Froling's new firewood boiler (15 - 20 kW) combines all the features of a state-of-the-art biomass combustion system. The speed-regulated induced draught fan ensures constant high quality combustion, and the carbonisation gas extraction system prevents flue gas from escaping, even when topping up. The new S1 Turbo stands out for its high efficiency and long refilling intervals, as well as its low emissions and low energy consumption.

The new air duct concept in Froling's S1 Turbo firewood boiler automatically regulates the heating, primary and secondary air with a single actuator. Thanks to the special air ducts for pre-heating, the fuel loading chamber door can be closed very soon after lighting. Heating with firewood can be that convenient!



## Pellet unit can be retrofitted at any time

The S1 Turbo F with pellet flange is the ideal solution for people who are currently only burning firewood. With the S1 Turbo F with pellet flange, the pellet unit can be retrofitted later at any time.

# The latest technology



## The firewood boiler with special benefits:

- 1 Speed-regulated, low-noise induced draught fan for maximum ease of use.
- 2 WOS system (Efficiency Optimisation System) as standard, for high efficiency and user-friendly cleaning from outside.
- 3 Large fuel loading chamber for logs up to 56 cm in length guarantees longer periods between refilling.
- 4 Top quality insulation to minimise radiant heat loss.
- 5 Lambdatronic S 3200 control with innovative bus technology.
- 6 Carbonisation gas extraction system prevents smoke escaping during reloading.
- 7 Cladding to protect the inner wall of the boiler and for a longer service life.
- 8 Air-cooled fuel loading chamber and cleaning door to minimise radiant heat loss.
- 9 Special automatic pre-heating with regulated air ducts.
- 10 Servomotor for automatic control of heating, primary and secondary air.
- 11 High-temperature firebrick-lined combustion chamber (easy to replace parts).
- 12 Large cleaning port door for easy ash removal and cleaning from the front.



## State-of-the-art technology and intelligent features



**Feature:** Large fuel loading chamber for logs up to 56 cm in length

- Advantages:
- Easy loading
  - Long combustion time
  - Long reloading intervals

The S1 Turbo can burn firewood up to a length of 56 cm. It is conveniently filled from the front, and the large loading chamber ensures long intervals between reloading. The aprons protect the interior walls of the boiler, guaranteeing a long service life.

# Intelligent features

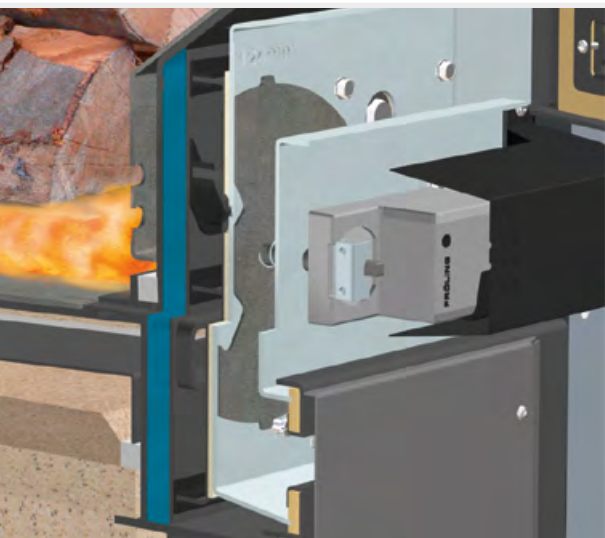

## **Feature: unique air duct system**

- Advantages:
- Regulated supply of air for pre-heating
  - Optimal combustion conditions

A unique design: both the primary and secondary air, as well as the heating air, are automatically regulated in the new S1 Turbo with just one servomotor. This means that in every stage of the heating process - from heating up to burnout - the exact amount of air is supplied, creating the perfect combustion conditions. Furthermore, thanks to the regulated air supply for pre-heating, the door can be closed just a short time after lighting. Heating with firewood can be that easy!

## **Feature: high-temperature firebrick-lined combustion chamber**

- Advantages:
- Low emissions
  - Easy cleaning
  - Long lifespan

The hot combustion zone in the combustion chamber keeps emissions levels low. The new shape of the combustion chamber makes it especially easy to clean. Furthermore, its new construction makes maintaining the combustion chamber a breeze as the firebricks are very easy to replace.

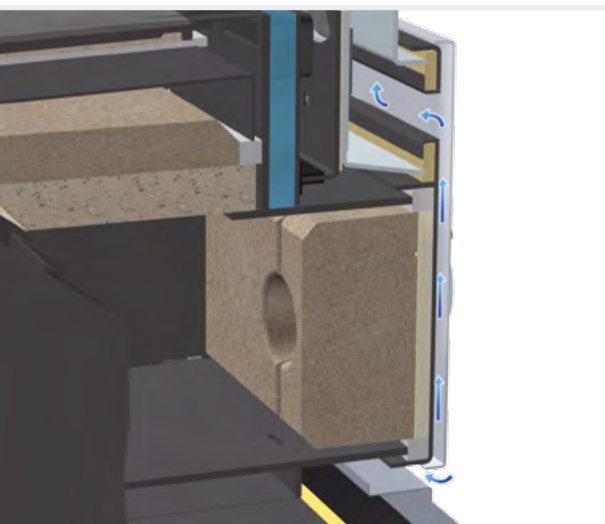
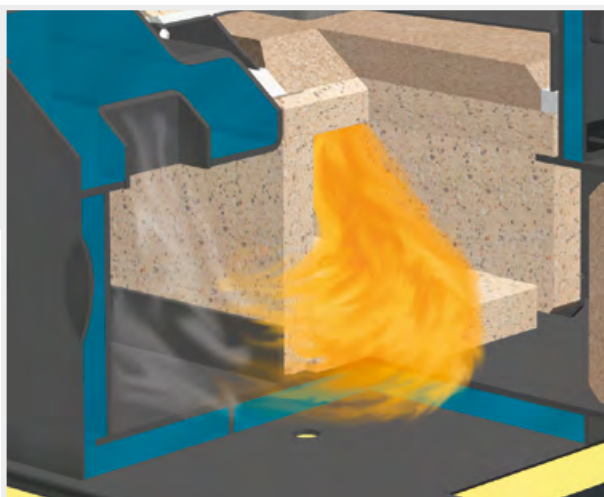

## **Feature: air-cooled fuel loading chamber and cleaning doors**

- Advantages:
- Maximum ease of use
  - Low radiant heat losses
  - High levels of efficiency

Thanks to the new air duct concept, the combustion air is taken in via the fuel loading chamber and combustion chamber doors. This air cooling ensures low temperatures at the boiler's operating elements, thus offering optimum convenience for the user. Furthermore, the low radiant heat losses guarantee excellent efficiency.

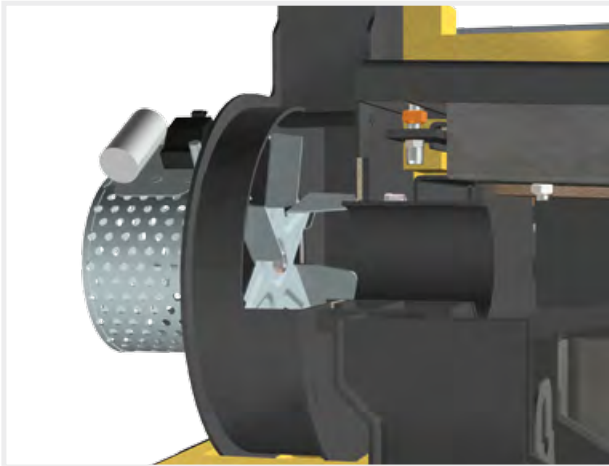

**Feature: speed-regulated induced draught fan**

- Advantages:
- Maximum ease of use
  - Smooth boiler start
  - Constant stabilisation during combustion

The speed-controlled induced draught fan is a standard component of the unit, which further enhances the reliability of the S1 Turbo. This means that the boiler can be started easily even if the chimney is cold. The speed regulation device in the induced draught fan stabilises combustion throughout the heating process and adjusts the output according to requirements.

**Feature: WOS system as standard**

- Advantages:
- Even more efficient
  - Easy cleaning from outside
  - Fuel economy

We never compromise on convenience. The WOS (Efficiency Optimization System), a standard part of the S1 Turbo, consists of special turbulators which are placed in the heat exchanger pipes. The lever arm mechanism ensures easy cleaning of the heating surfaces from the outside. An additional benefit of this mechanism is that it ensures higher efficiency and fuel savings.

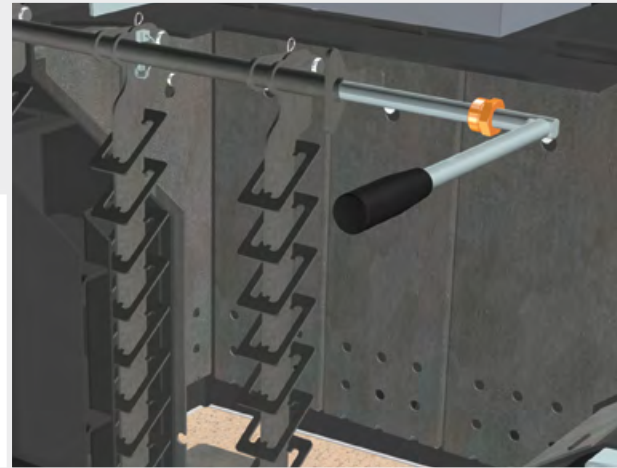

**Feature: special carbonisation gas extraction system**

- Advantages:
- Easy pre-heating
  - No flue gas escapes during reloading
  - Boiler room stays clean

The integrated carbonisation gas duct flap makes pre-heating even easier. The flap is closed manually before lighting to provide a better draught during the pre-heating process. The carbonisation gas duct flap opens automatically when the fuel loading chamber door is closed. This then reactivates the carbonisation gas extraction system, thus preventing smoke and gas from escaping when reloading.

**Feature: Pellet flange for the S1 Turbo F (optional)**

- Advantages:
- Pellet unit can be retrofitted at any time
  - Two systems perfectly combined

The S1 Turbo F with pellet flange is the ideal solution for people who are currently only burning firewood. With the S1 Turbo F with pellet flange, the pellet unit can be retrofitted at any time.



# Systematic convenience

## **Feature: Lambdatronic S3200 Control System**

- Advantages:
- Exact combustion control with broadband lambda control
  - Large, clear control unit
  - Boiler console with touch display (optional)



With the Lambdatronic SP 3200 boiler controller and touch display, Froling is taking a step into the future. Intelligent control management makes it possible to connect up to 18 heating circuits, up to 4 storage tanks and up to 8 hot water storage tanks. The control unit ensures that the operating statuses are clearly shown. The menu structure is ideally organised to allow easy operation. All essential functions can be selected by simply pressing icons on the colour display.

## **Accessories for even greater ease of use (optional)**



### **FRA room temperature sensor**

By using the Froling FRA room temperature sensor (measuring only 8x8 cm), the main modes of the corresponding heating circuit can be easily selected and adjusted. The FRA room temperature sensor can be connected with or without affecting the room area. The adjusting wheel allows you to change the room temperature by up to  $\pm 3^{\circ}\text{C}$ .



### **RBG 3200 room console**

The RBG 3200 room console makes the system even easier to use. The heating system is conveniently controlled from your living room. All important system data is clearly displayed on the 19x8 cm console and settings can be changed at the push of a button.

### **RBG 3200 Touch Room console**

The RBG 3200 Touch has an impressive touchpad interface. The menu structure means it is intuitive and easy to use. The colour console screen (measuring approx. 17x10 cm) shows the most important functions at a glance and automatically adjusts the background lighting to the conditions. The room console is connected to the boiler controller using a bus cable.



## NEW: froeling-connect.com online control

Froeling's new online control, froeling-connect.com, allows you to check and control your Froeling boiler with boiler touch display anytime anywhere. You can read or modify the main status information and settings easily and conveniently online (from your PC, smartphone, tablet PC, etc.). You can also specify which status messages you would like to receive by text message or e-mail. The new froeling-connect.com service allows the owner of the heating system to enable additional users - for example the installer, a neighbour, etc. - to access the boiler and monitor the heating system, during holidays for instance.



Customer  
Installer  
Customer service

Individual  
access rights



Operates on  
all platforms  
Operate the heating  
system online



System requirements:

- Froeling boiler (core module software version V54.04, B05.09) with boiler touch display (software version V60.01, B01.20)
- Broadband internet connection
- Froeling boiler internet connection via network
- Web-enabled terminal device (smartphone/tablet PC/laptop/PC) with web browser

## Feature: Froeling visualisation software 3200

- Advantages:
- Monitor and operate from your PC
  - Record boiler data
  - Remote control via modem

The optional boiler visualisation software enables easy boiler control from a computer. All operating values and customer parameters can be displayed and modified. The familiar Windows interface and clear menu structure make it easy to use. It is possible to connect to the visualisation software using a telephone network modem. This means that the heating system can be monitored from any location. It is also possible to connect to an existing LAN using an optional adapter.



## Feature: Froeling SMS Box

- Advantages:
- Text message alerts
  - Active heating system control

The Froeling SMS box allows you to monitor the boiler and actively control the heating system by text message. It can be programmed directly from a mobile phone and has two error message inputs and two remote switch outputs. The alarm and message texts can be configured as required. This includes switching, e.g. from setback mode to party mode (only in conjunction with room temperature sensor). An automatic response confirms the execution of the command that was sent.



# Systematic convenience

**Feature:** systems engineering for optimum energy consumption

- Advantages:
- Complete solutions for all requirements
  - Components work perfectly together
  - Integrated solar power

The perfect combination – Please also see our "Tank systems" brochure

Frothing systems engineering offers efficient energy management. Up to 4 storage tanks, 8 hot water tanks and 18 heating circuits can help manage the heating. You can also benefit from the ability to integrate other means of energy production such as solar panel systems.

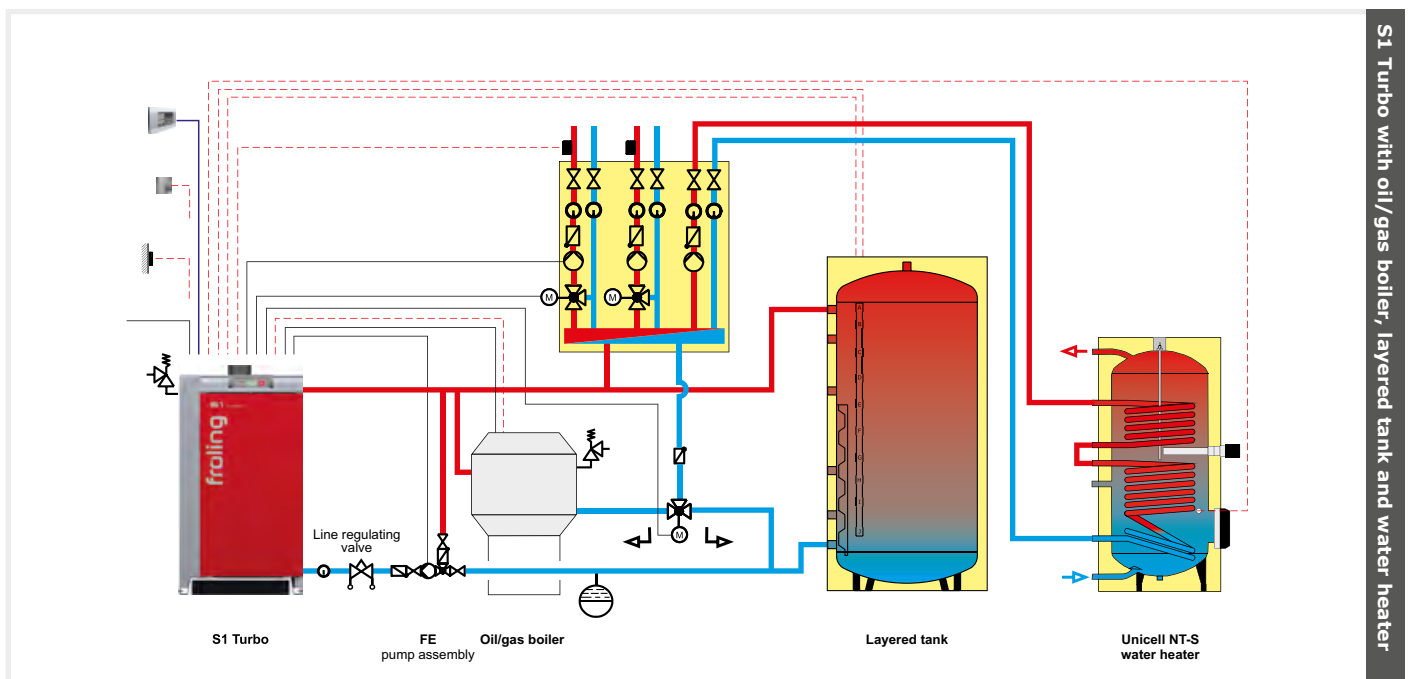
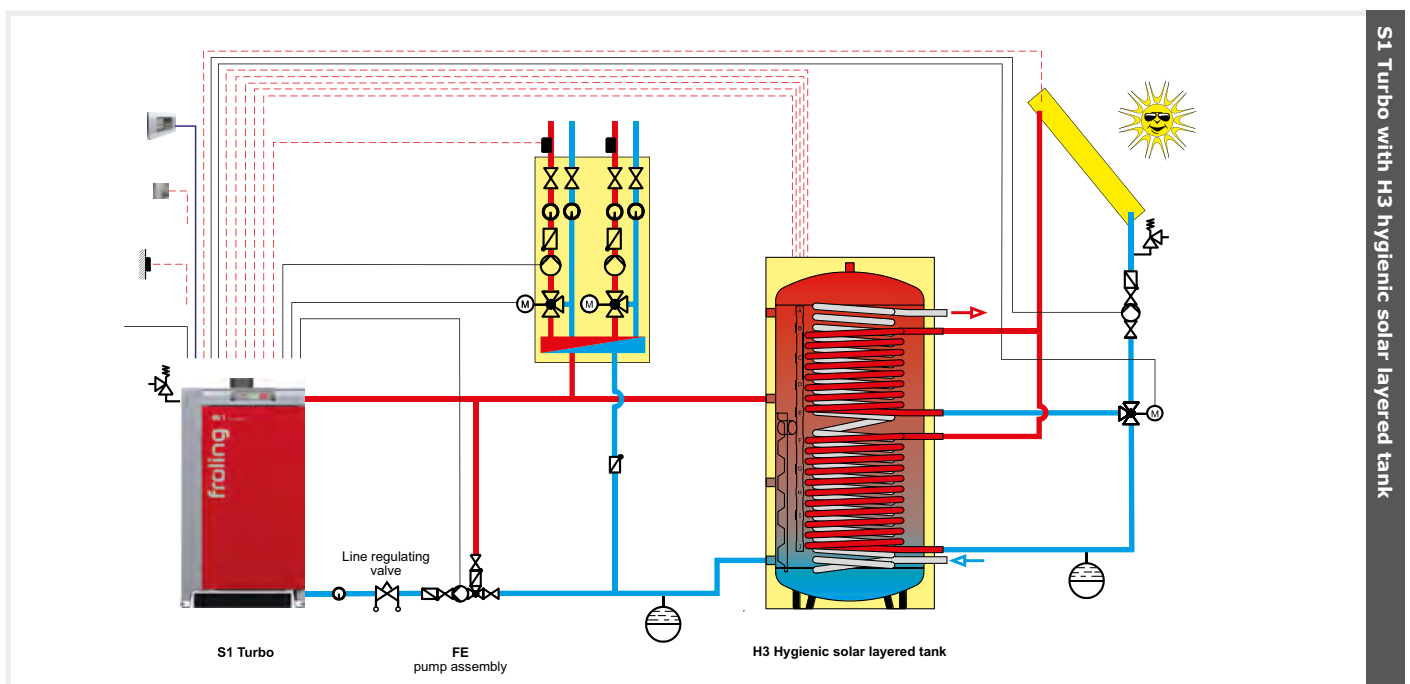

## Minimum distances in the boiler room

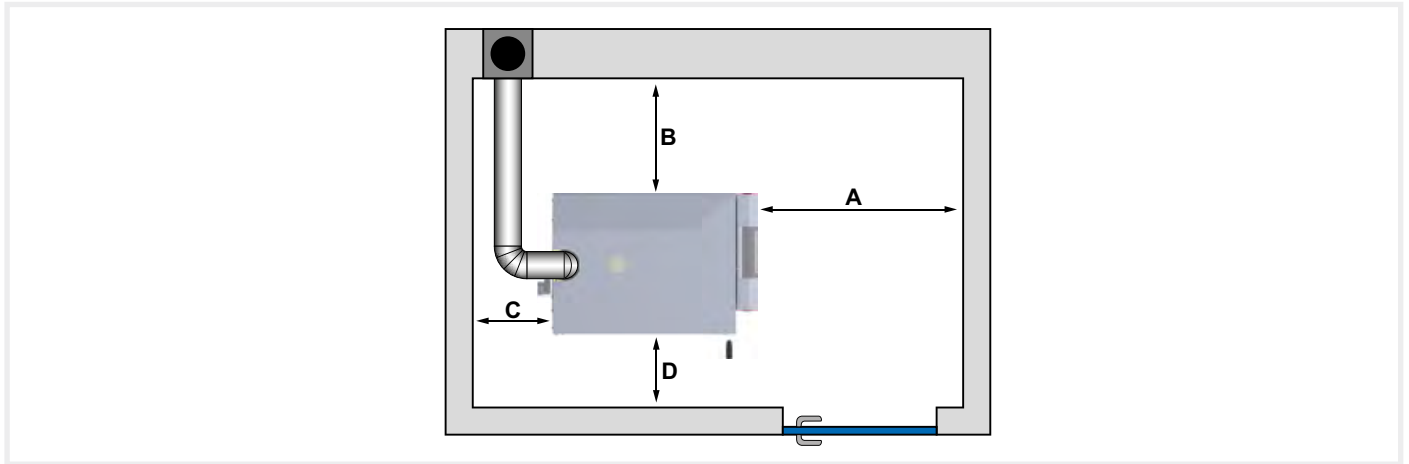

Minimum distances - S1 Turbo		15	20
A	Distance between front of boiler and wall [mm]	800	800
B	Distance between side of boiler and wall [mm]	500	500
C	Distance between rear of boiler and wall [mm]	400	400
D	Distance between side of boiler with WOS lever and wall [mm]	500 (200 <sup>1</sup> )	500 (200 <sup>1</sup> )

<sup>1</sup> Maintenance on the boiler heat exchanger is only possible from the front

More information can be found in our "SP Dual Compact" brochure

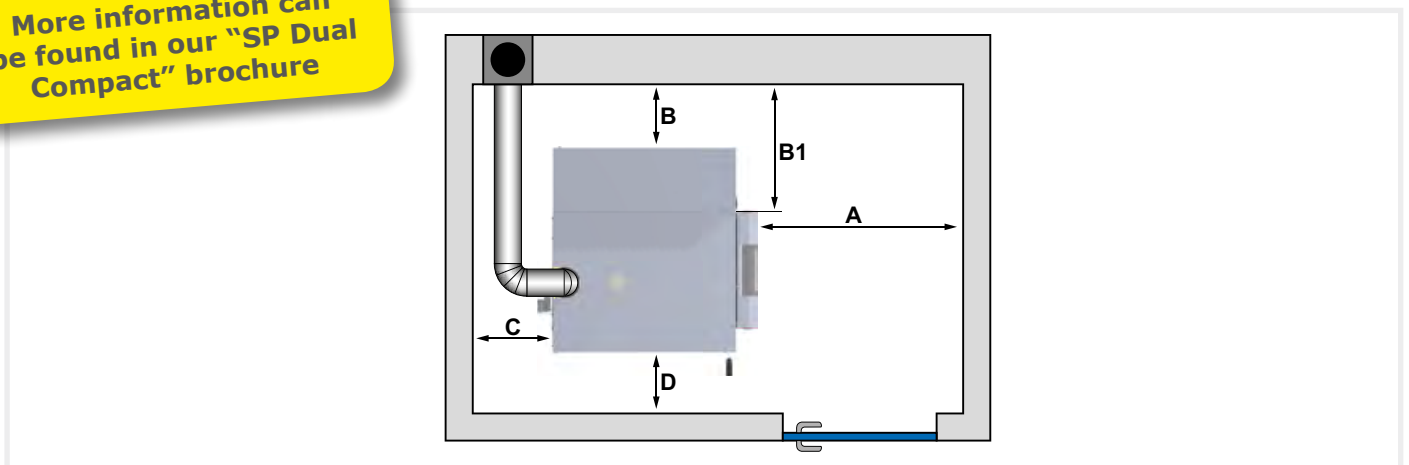

Minimum distances - S1 Turbo F (SP Dual Compact)		15	20
A	Distance between front of boiler and wall [mm]	800	800
B	Distance between side of boiler with heat exchanger lever and pellet unit and wall [mm]	500	500
B1	Distance between side of boiler without pellet unit and wall [mm]	815	815
C	Distance between rear of boiler and wall [mm]	400	400
D	Distance between side of boiler with WOS lever and wall [mm]	500 (200 <sup>1</sup> )	500 (200 <sup>1</sup> )

<sup>1</sup> Maintenance on the boiler heat exchanger is only possible from the front

# Technical specifications

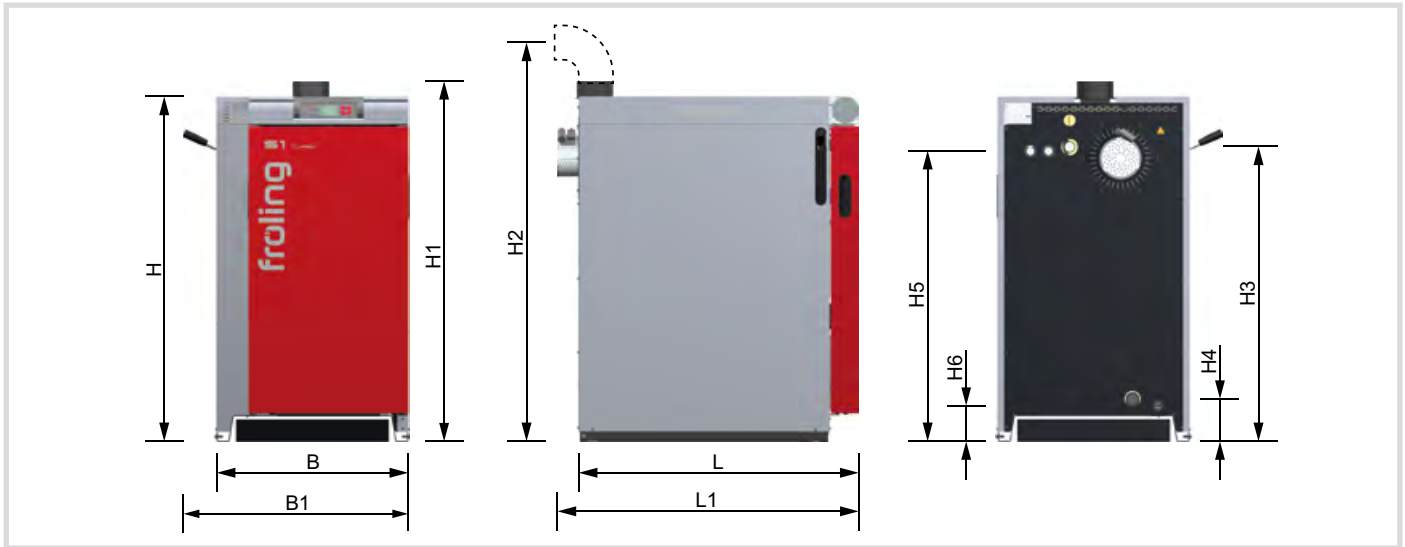

Dimensions - S1 Turbo		15	20
L	Length of boiler [mm]	1000	1000
L1	Total length including induced draught fan [mm]	1080	1080
B	Width of boiler [mm]	685	685
B1	Width of boiler incl. WOS lever [mm]	790	790
H	Height of boiler [mm]	1235	1235
H1	Total height incl. flue gas nozzle [mm]	1300	1300
H2	Height, flue gas pipe connection [mm]	1450	1450
H3	Height, flow connection [mm]	1055	1055
H4	Height, return connection [mm]	150	150
H5	Height, safety battery connection [mm]	1040	1040
H6	Height, drain [mm]	125	125
	Flue pipe diameter [mm]	130	130

Technical specifications - S1 Turbo		15	20
Nominal output	[kW]	15	20
Power connection	[V/Hz/A]	230V / 50Hz / fused C16A	
Power consumption	[W]	37	42
Weight of boiler incl. insulation and control	[kg]	455	465
Dimensions of fuel loading door (width/height)	[mm]	360 / 360	360 / 360
Fuel loading chamber capacity	[l]	80	80

Your Froling partner:



**Heizkessel- und Behälterbau GesmbH  
A-4710 Grieskirchen, Industriestr. 12**

AUT: Tel +43 (0) 7248 606 • Fax +43 (0) 7248 606-600  
GER: Tel +49 (0) 89 927 926-0 • Fax +49 (0) 89 927 926-219  
Email: [info@froeling.com](mailto:info@froeling.com) • Internet: [www.froeling.com](http://www.froeling.com)